

FT742-PM (PIPE MOUNT)



ACOUSTIC RESONANCE WIND SENSOR

DESIGNED FOR TURBINE CONTROL

The FT742 Pipe Mount wind sensor is designed for installation on top of a pipe or post. The sensor cable is run inside the pipe giving added lightning and environmental protection. Factory alignment of the pipe mount adapter ensures that the sensor is automatically aligned with the central axis of the turbine without error.

Measuring wind speeds up to 75m/s it is suitable for use in the stormiest areas of the world.

The thermostatically controlled heating system prevents ice build-up, not only on the sensor itself, but also on the metal adapter and pipe. This prevents blockage of the measurement cavity, reducing turbine downtime during heavy icing events.

Designed to last for up to 20 years, even in an offshore environment, the Pipe Mount sensor is used by turbine manufacturers around the world. Highly resistant to electromagnetic and acoustic interference, it is also an ideal choice for smaller-scale wind turbines.

DIMENSIONS

A. Sensor height.....	161mm
B. Sensor width max.....	56mm
C. Adaptor mating surface (hidden) to cavity centre.....	90mm
D. Alignment notch width.....	5.1mm
E. I/O connector width max.....	22mm
F. Mounting flange width.....	45mm

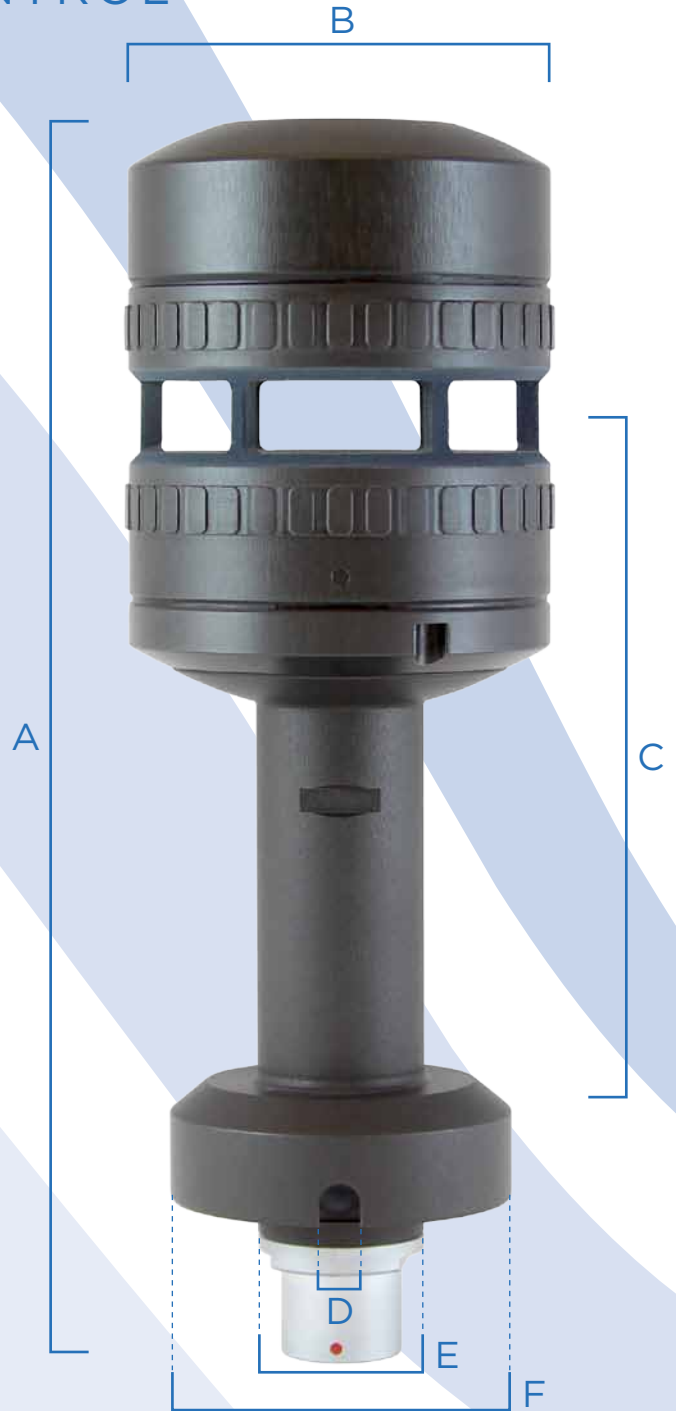

SPECIFICATIONS AT A GLANCE

WIND SPEED

0-75 m/s

WEIGHT

350 g

AVAILABILITY

> 99.9 %

FT742-PM (PIPE MOUNT)

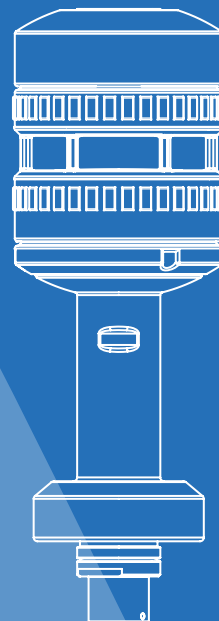

WIND SPEED

Range.....	0-75m/s
Resolution.....	0.1m/s
Accuracy.....	±0.3m/s (0-16m/s) ±2% (16-40m/s) ±4% (40-75m/s)

WIND DIRECTION

Range.....	0 to 360°
Resolution.....	1°
Accuracy (within ±10° datum).....	2° RMS
Accuracy (outside ±10° datum).....	4° RMS

SENSOR PERFORMANCE

Measurement principle.....	Acoustic Resonance (automatically compensates for variations in temperature, pressure & humidity)
Units of measure.....	Metres per second, kilometres per hour or knots
Altitude.....	0-4000m operating range
Temperature range.....	-40° to +85°C (operating and storage)
Humidity.....	0-100%
Ingress protection.....	IP66 and IP67, EN 60529
Heater settings.....	0° to 55°C. The heater set point can be configured

POWER REQUIREMENTS

Supply voltage.....	20V to 30V DC (24V DC nominal)
Supply current (heater off).....	31mA typical
Supply current (heater on).....	Limited to 4A (default), 6A (max) – configurable in software in 0.1A increments. Heater power consumption will depend on the energy required to keep the sensor's temperature at the user determined set point. The heater and sensor power consumption is limited by default to 99W.

PHYSICAL

I/O connector.....	5-way (RS485 option), 8-way (4-20mA option) multipole connector
Sensor weight.....	350g

DIGITAL SENSOR

Interface.....	RS485, galvanically isolated from power supply lines and case
Format.....	ASCII data, polled or continuous output modes, NMEA 0183
Data update rate.....	Maximum 10 measurements per second
Error handling.....	When the sensor detects an invalid reading a character is set in the wind velocity output message. This error flag character is 1

ANALOGUE SENSOR

Interface.....	4-20mA, galvanically isolated from power supply lines and case.
Format.....	One 4-20mA current loop for wind speed (different scaling factors are available). One 4-20mA current loop for wind direction (datum value configurable as 4mA or 12mA). Both analogue channels are updated ten times per second.
4-20mA configuration port.....	This port is for the user to change the internal settings of analogue sensors and to perform diagnostic testing. This interface is not intended for permanent connection to a data logger or other device.
Error handling.....	When the sensor detects an invalid reading then both speed and direction current loops will drop to a default value of 1.4mA (configurable up to 3.9mA).

EMC AND ENVIRONMENTAL TESTS

The FT7 Series have passed over 28 different environmental test certificates including Corrosion, Icing, De-Icing, Shock, Hail, Drop, ESD, short circuit, power interruption and EMC. Further test details and full test reports available on request or via our website.